

# *The PXI Modular Instrumentation Architecture*

## **Overview**

The PXI (PCI eXtensions for Instrumentation) specification defines a rugged PC platform for measurement and automation. PXI modular instrumentation leverages the high-speed PCI (Peripheral Component Interconnect) Bus which is the de facto standard driving today's desktop computer software and hardware designs. As a result, PXI users can enjoy all the benefits of PCI within an architecture that supports mechanical, electrical, and software features that make sense for test and measurement, data acquisition, and industrial computing applications.

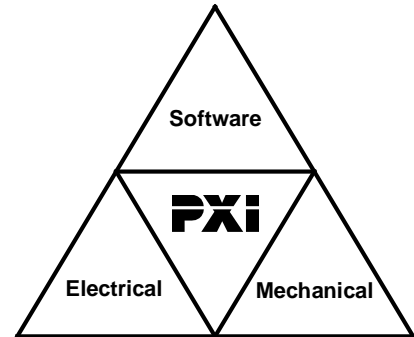

The PXI specification, now at revision 2.0, leverages the CompactPCI specification, which defines a rugged form factor for PCI that offers superior mechanical integrity and easy installation and removal of hardware components. PXI products offer higher and more carefully defined levels of environmental performance required by the vibration, shock, temperature, and humidity extremes of industrial environments. PXI adds mandatory environmental testing, EMC testing, and active cooling to the CompactPCI mechanical specification to ease system integration and ensure multi-vendor interoperability.

PXI offers the same high-performance electrical features as PCI including 132 MB/sec data rates and Plug-and-Play functionality. The most compelling benefit for PXI, however, is PCI's dominance in the desktop PC marketplace which is served by over 800 suppliers. The result is widespread availability of PCI-based silicon, firmware, drivers, operating systems, and software applications – all of which can be applied cost-effectively in PXI-based systems. As with CompactPCI, PXI offers nearly twice as many peripheral slots as desktop PCI systems per bus segment. Thus, multiple-segment PXI systems can offer far more slots than extended desktop systems resulting in far more I/O capability. Additionally, PXI meets the more specific needs of instrumentation users by adding an integrated Trigger Bus and Reference Clock for multi-board synchronization, a Star Trigger Bus for very precise timing, and Local Buses for side-band communication between adjacent peripherals.

PXI defines system-level software requirements for standard frameworks such as Microsoft Windows NT and 98 which already have millions of users of thousands of applications. This preserves multi-vendor compatibility and eases system integration tasks. Furthermore, all PXI peripherals must include appropriate device driver software eliminating costly end-user development efforts.

As a result of PXI's mechanical, electrical, and software features, instrumentation system developers acquainted with applications designed for desktop PCs can immediately leverage these resources in a more rugged PXI form factor at an incremental cost.

## Mechanical Features

PXI modular instrumentation offers mechanical features that make PXI systems well-suited for industrial environments and make them easy to integrate. The rugged Eurocard packaging system and high-performance IEC connectors called out by CompactPCI are also used in PXI. PXI adds specific cooling and environmental requirements. Finally, two-way interoperability with standard CompactPCI systems is offered through the PXI specification.

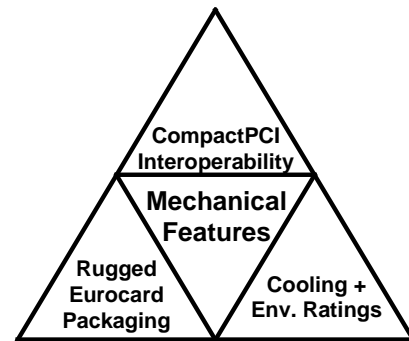

The following PXI mechanical features are shared with CompactPCI:

### High Performance Connector System

PXI employs the same advanced pin-in-socket connector system called out by CompactPCI. These highly dense (2mm pitch) impedance-matched connectors are defined by the International Electrotechnical Commission (IEC-1076) and offer the best possible electrical performance under all conditions. These connectors have seen widespread use in high-performance applications particularly in the telecommunications field.

### Eurocard Mechanical Packaging and Form Factors

The mechanical aspects of PXI and CompactPCI are governed by Eurocard specifications (ANSI 310-C, IEC 297, and IEEE 1101.1) which have a long history of application in industrial environments. A small (3U=100mm by 160mm) and a large (6U=233.35mm by 160mm) form factor are supported. Figure 1 shows the two primary form factors and the associated interface connectors for PXI peripheral boards. The most recent additions to the Eurocard specifications (IEEE 1101.10 and 1101.11) address electromagnetic compatibility, user-defined mechanical keying, and other packaging issues that apply to PXI systems. These electronics packaging standards define compact, rugged systems that can withstand harsh industrial environments in rack mount installations.

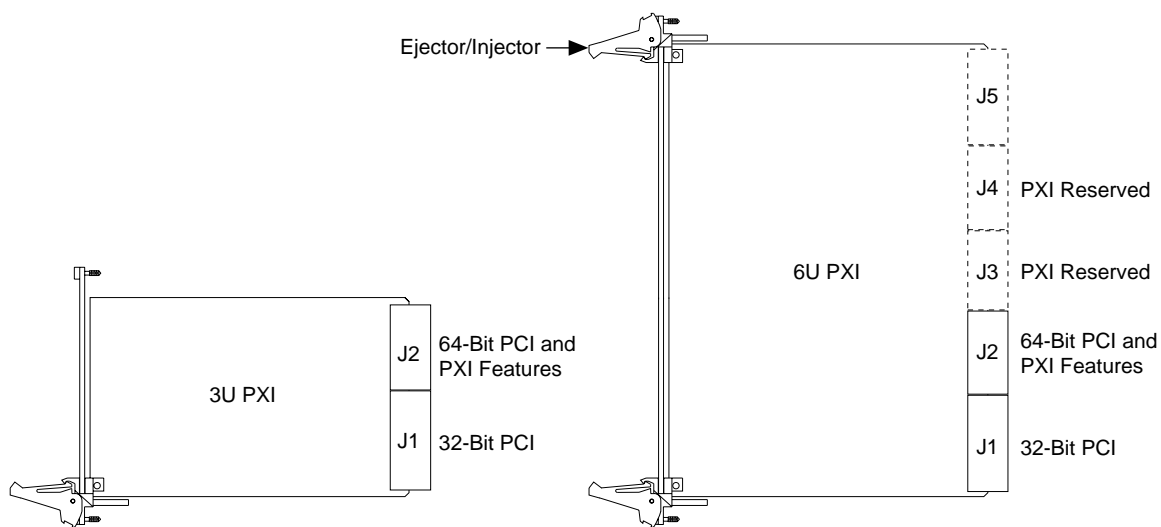

**Figure 1. PXI Peripheral Board Form Factors and Connectors**

All PXI features are implemented on the J2 connector of a 3U board and may selectively be used by peripheral boards. PXI compatible backplanes must implement the complete PXI feature set. 6U PXI boards and PXI chassis only need to implement connectors J1 and J2. Future additions to the PXI specification may define the pinouts for connectors J3 and J4 for additional functionality in 6U. Note that any 3U peripheral board can work in a 6U chassis by using a simple adapter panel.

PXI defines the system slot location to be on the far left end of the bus segment as shown in the system diagram of Figure 2. This defined arrangement is a subset of the numerous possible configurations allowed by CompactPCI (a CompactPCI system slot may be located in any single position on a backplane). Defining a single location for the system slot simplifies integration and increases the degree of compatibility between controllers and chassis from multiple vendors. Furthermore, the PXI specification stipulates that the System Controller board should expand to the left into what are defined as controller expansion slots. These expansion slots do not have any CompactPCI connectors associated with them on the backplane and are basically expansion space. Expanding to the left prevents system controllers from using up valuable peripheral slots.

### **Additional Electronic Packaging Specifications**

All mechanical specifications defined in the CompactPCI specification apply directly to PXI systems; however, PXI does include additional requirements that simplify system integration. As discussed above, the system slot in a PXI chassis must be located in the leftmost slot and controllers should be designed to expand to the left to avoid using up peripheral slots. The airflow direction for required forced-cooling of PXI boards is defined to flow from the bottom to the top of a board. The PXI

specification recommends complete environmental testing including temperature, humidity, vibration, and shock for all PXI products and requires documentation of test results. Operating and storage temperature ratings are required for all PXI products. Electromagnetic emissions and susceptibility testing is also required by the PXI specification to ensure compliance with international standards.

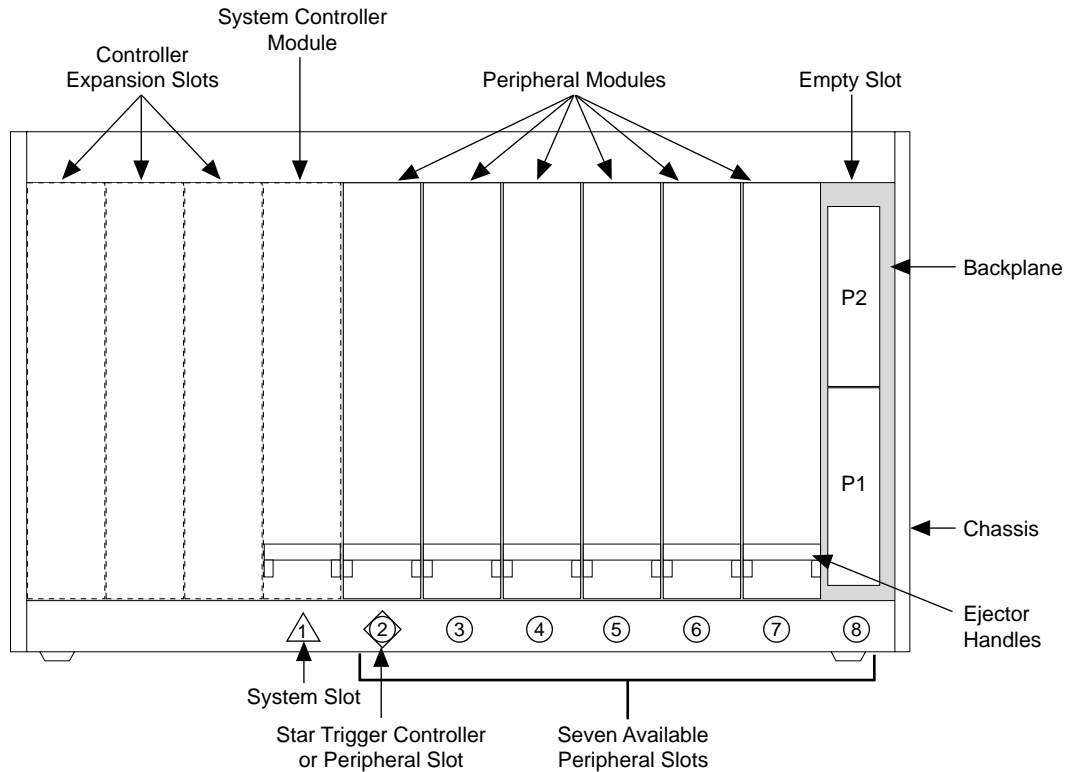

**Figure 2. Example of a 3U PXI System**

### Interoperability with CompactPCI

An important feature offered by PXI is that it maintains interoperability with standard CompactPCI products. Many PXI compatible systems may require components that do not implement PXI-specific features. For example, a user may want to use a standard CompactPCI network interface card in a PXI chassis. Likewise, some users may choose to use a PXI compatible plug-in card in a standard CompactPCI chassis. In this case the user will not be able to implement PXI-specific functions but will still be able to use the plug-in card's basic functions. Note that interoperability between PXI compatible products and certain application-specific implementations of CompactPCI (other sub-buses) is not guaranteed. Of course both CompactPCI and PXI leverage the PCI Local Bus which ensures software and electrical compatibility as depicted in Figure 3.

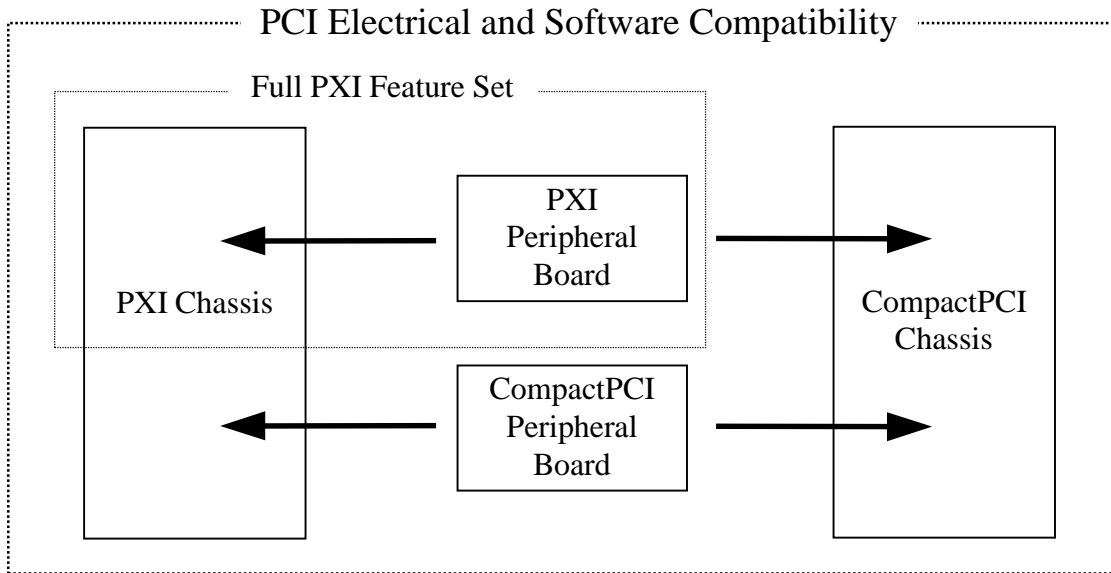

**Figure 3. PXI and CompactPCI Interoperability**

## Electrical Features

Many instrumentation applications require system timing capabilities that cannot be implemented directly across standard ISA, PCI, or CompactPCI backplanes. PXI modular instrumentation adds a dedicated system reference clock, bused trigger lines, star triggers, and slot-to-slot local buses to address the need for advanced timing, synchronization, and side-band communication. PXI adds these instrumentation features while maintaining all of the advantages of the PCI bus. Finally, PXI offers three more peripheral slots per bus segment than desktop PCI for a total of seven.

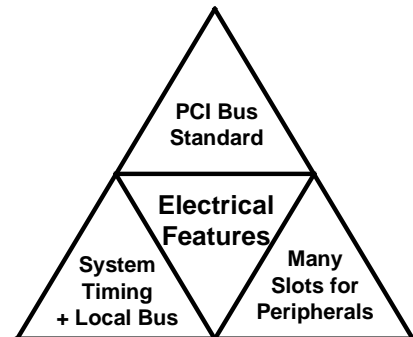

### System Reference Clock

PXI defines the means to distribute a 10 MHz system reference clock to all peripheral devices in a system. This reference clock can be used for synchronization of multiple cards in a measurement or control system. The implementation of the reference clock on the backplane is strictly defined. As a result, the low skew qualities afforded by this reference clock make it ideal for qualifying individual clock edges of trigger bus signals for sophisticated trigger protocols.

### Trigger Bus

PXI defines eight highly flexible bused trigger lines that may be used in a variety of ways. For example, triggers can be used to synchronize the operation of several different PXI peripheral boards. In other applications, one board can control carefully timed sequences of operations performed on other boards in the system.

Triggers may also be passed from one board to another allowing deterministic responses to asynchronous external events that are being monitored or controlled. The number of triggers that a particular application requires varies with the complexity and number of events involved.

## **Star Trigger**

The PXI star trigger bus offers ultra-high performance synchronization features to users of PXI systems. The star trigger bus implements a dedicated trigger line between the first peripheral slot (adjacent to the System Slot) and the other peripheral slots. An optional star trigger controller can be installed in this slot to provide very precise trigger signals to other peripheral boards. Systems that don't require this advanced trigger can install any standard peripheral board in this slot. Note that the star trigger can be used to communicate information back to the star trigger controller as in the case of reporting a slot's status as well as responding to information provided by the controlling slot.

PXI's star trigger architecture gives two unique advantages in augmenting the bused trigger lines. The first is a guarantee of a unique trigger line for each card in the system. For large systems, this eliminates the need to combine multiple card functions on a single trigger line or to artificially limit the number of trigger times available. The second advantage is the low-skew connection from a single trigger point. The PXI backplane defines specific layout requirements such that the star trigger lines provide matched propagation time from the star trigger slot to each card for very precise trigger relationships between each card.

## **Local Bus**

The PXI local bus is a daisy-chained bus that connects each peripheral slot with its adjacent peripheral slots to the left and right. Thus, a given peripheral slot's right local bus connects to the adjacent slot's left local bus and so on. Each local bus is 13 lines wide and can be used to pass analog signals between cards or to provide a high speed side-band communication path which does not affect the PCI bandwidth.

Local bus signals may range from high-speed TTL signals to analog signals as high as 42 volts. Keying of adjacent boards is implemented by initialization software that prohibits the use of incompatible boards. Boards are required to initialize their local bus pins in a high-impedance state and can only activate local bus functionality after configuration software has determined that adjacent boards are compatible. This method provides a flexible means for defining local bus functionality that is not limited by hardware keying.

The local bus lines for the leftmost peripheral slot on a PXI backplane is used for the star trigger. This is represented in the local bus schematic in Figure 4.

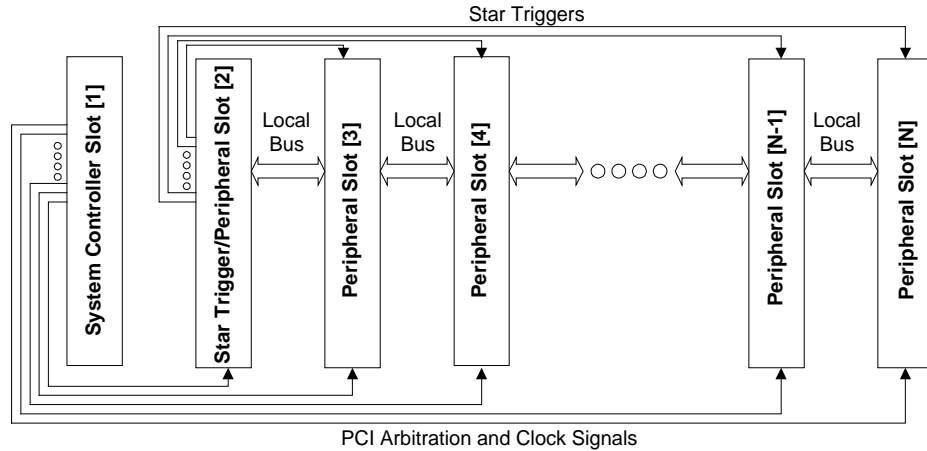

**Figure 4. PXI Local Bus Routing**

## Peripheral Component Interconnect (PCI) Features

PXI offers the same performance features defined by the desktop PCI specification with one notable exception. A PXI system can have up to eight slots per segment (1 system slot + 7 peripheral slots), whereas most desktop PCI systems only offer three or four available peripheral slots. Multiple-segment PXI systems built using PCI-PCI bridges offer this increased number of slots per segment making very high slot count systems possible (256-slot theoretical maximum). The capability to have additional peripheral slots is defined in the CompactPCI specification upon which PXI draws. Otherwise all of PCI's features transfer to PXI:

- 33 MHz performance
- 32- and 64-bit data transfers
- 132 MB/sec (32-bit) and 264 MB/sec (64-bit) peak data rates
- System expansion via PCI-PCI bridges
- 3.3 volt migration
- Plug-and-play capability

## Software Features

Like other bus architectures, PXI defines standards that allow products from multiple vendors to work together at the hardware interface level. Unlike many other specifications, however, PXI defines software requirements in addition to electrical requirements to further ease integration. These requirements include the support of standard operating system frameworks such as Windows NT and 98 (WIN32). Appropriate configuration information and software drivers for all peripheral devices are also required. Clearly, the PXI software specification is motivated by the benefits achieved through leveraging existing desktop software technology.

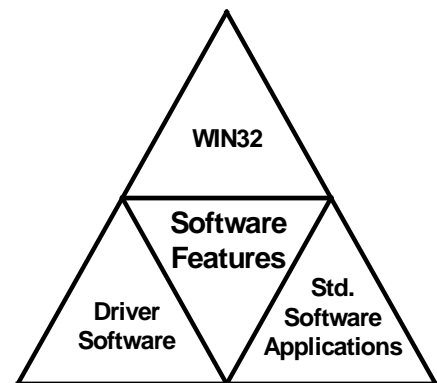

## **Common Software Requirements**

The PXI specification presents software frameworks for PXI systems including Microsoft Windows NT and 98. A PXI controller operating in either framework must support the currently available operating system and must support future upgrades. As a result, the controller will be able to use industry-standard application programming interfaces including LabVIEW, LabWindows/CVI, Visual Basic, Visual C/C++ and Borland Turbo C++.

PXI requires that all peripheral cards have device driver software that runs in the appropriate framework. Hardware vendors for other industrial buses that do not have software standards often do not provide any software drivers for their devices. The customer is often only given a manual, which describes how to write software to control the device. The cost to the customer, in terms of engineering effort, to support these devices can be enormous. PXI removes this burden by requiring that manufacturers, rather than customers, develop this software.

## **Other Software Requirements**

PXI also requires certain software components to be made available by peripheral board and chassis vendors. Initialization files that define a system's configuration and capabilities are required for PXI components. This information is used by the operating software to ensure proper configuration of a system. For example, this mechanism is used to identify whether or not adjacent peripheral boards have a compatible local bus. If any information is missing, the local bus functionality cannot be accessed. Finally, implementation of the Virtual Instrument Software Architecture (VISA), which has been widely adopted in the instrumentation field, is specified by PXI for configuration and control of VXI, GPIB, serial, and PXI instruments.

## **Conclusions**

PXI modular instrumentation makes sense because it defines an industrial computing platform for instrumentation users that clearly leverages the technology advancements of the mainstream PC industry. By leveraging the PCI Bus, PXI modular instrumentation systems can benefit from widely available software and hardware components. The software applications and operating systems that run on PXI systems are already familiar to end-users as they are already in use on common desktop PCI computers. PXI meets the needs of instrumentation users by adding rugged industrial packaging, plentiful slots for virtually unlimited I/O, and features that provide advanced triggering, timing, and side-band communication capabilities.